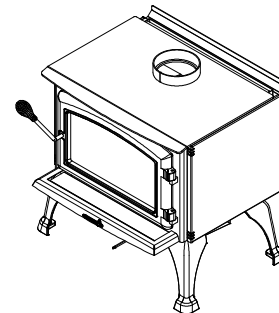
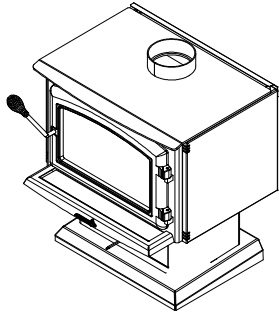
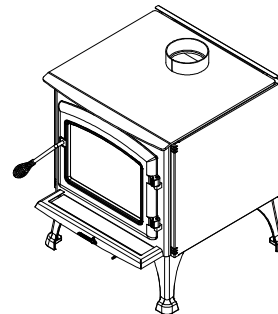
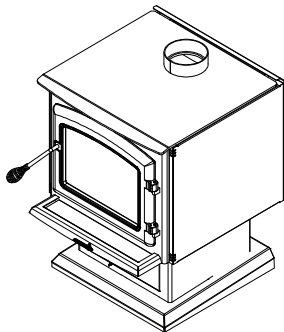


## ENERZONE E.P.A. WOOD STOVE MANUAL

### Solution 1.8



### Solution 2.9



US ENVIRONMENTAL  
PROTECTION AGENCY  
PHASE II CERTIFIED  
WOOD STOVE



Fabriqué par :  
**STOVE BUILDER INTERNATIONAL INC.**  
250, rue de Copenhague,  
Saint-Augustin-de-Desmaures  
(Quebec) G3A 2H3  
After-sale service: 418-908-8002  
E-mail: tech@sbi-international.com

[www.enerzone-intl.com](http://www.enerzone-intl.com)

Verified and tested  
following ULC S627  
and UL 1482 Standards  
by an accredited  
laboratory

READ AND KEEP THIS MANUAL FOR REFERENCE



*This manual is available for free download on the manufacturer's web site. It is a copyrighted document. Re-sale is strictly prohibited. The manufacturer may update this manual from time to time and cannot be responsible for problems, injuries, or damages arising out of the use of information contained in any manual obtained from unauthorized sources.*

## **INTRODUCTION**

Stove Builder International, one of the most important wood stove and fireplace manufacturers in North America, congratulates you on your purchase and wishes to help you get maximum satisfaction from your wood stove. In the pages that follow, we will give you advice on wood heating and controlled combustion as well as technical specifications regarding installation, operation and maintenance of the model you have chosen.

The instructions pertaining to the installation of your wood stove in North America comply with ULC-S627 and UL-1482 standards.

We recommend that our wood burning hearth products be installed and serviced by professionals who are certified in the United States by NFI (National Fireplace Institute®) or in Canada by WETT (Wood Energy Technology Transfer) or in Quebec by APC (Association des Professionnels du Chauffage).

**Read this entire manual before you install and use your new stove. If this stove is not properly installed, a house fire may result. To reduce the risk of fire, follow the installation instructions. Failure to follow instructions may result in property damage, bodily injury, or even death.**

**Consult your municipal building department or fire officials about restrictions and installation requirements in your area and the need to obtain a permit.**

**KEEP THIS INSTRUCTIONS MANUAL FOR FUTURE REFERENCE.**

### **CAUTIONS:**

- THE INFORMATION GIVEN ON THE CERTIFICATION LABEL AFFIXED TO THE APPLIANCE ALWAYS OVERRIDES THE INFORMATION PUBLISHED, IN ANY OTHER MEDIA (OWNER'S MANUAL, CATALOGUES, FLYERS, MAGAZINES AND/OR WEB SITES).
- HOT WHILE IN OPERATION. KEEP CHILDREN, CLOTHING AND FURNITURE AWAY. CONTACT MAY CAUSE SKIN BURNS.
- DO NOT USE CHEMICALS OR FLUIDS TO IGNITE THE FIRE.
- DO NOT LEAVE THE STOVE UNATTENDED WHEN THE DOOR IS SLIGHTLY OPENED DURING IGNITION.
- DO NOT BURN WASTE, FLAMMABLE FLUID SUCH AS GASOLINE, NAPHTHA, OR MOTOR OIL.
- DO NOT CONNECT TO ANY AIR DISTRIBUTION DUCT OR SYSTEM.
- ALWAYS CLOSE THE DOOR AFTER IGNITION.

# TABLE OF CONTENTS

<b>1.</b>	<b>INSTALLATION</b>	<b>4</b>
<b>1.1</b>	<b>GENERAL INSTALLATION</b>	<b>4</b>
1.1.1	Pedestal or leg kit assembly	5
1.1.2	Installation of the decorative u-shaped inserts	6
1.1.3	Door overlay installation	6
1.1.4	Optional air mate installation	7
<b>1.2</b>	<b>POSITIONING THE STOVE</b>	<b>8</b>
<b>1.3</b>	<b>CLEARANCES TO COMBUSTIBLES AND FLOOR PROTECTOR</b>	<b>8</b>
<b>2.</b>	<b>CHIMNEY (FLUE SYSTEM)</b>	<b>14</b>
<b>2.1</b>	<b>DEFINITIONS</b>	<b>14</b>
<b>2.2</b>	<b>CHIMNEY</b>	<b>14</b>
2.2.1	Step by step installation of your factory-built chimney	16
2.2.2	Typical installation through an existing masonry chimney	19
<b>2.3</b>	<b>CHIMNEY CONNECTOR</b>	<b>21</b>
<b>2.4</b>	<b>DRAFT</b>	<b>23</b>
<b>2.5</b>	<b>FRESH AIR INTAKE KIT</b>	<b>23</b>
<b>2.6</b>	<b>THE ADVANTAGE OF INSTALLING A BLOWER</b>	<b>24</b>
<b>3.</b>	<b>OPERATION</b>	<b>25</b>
<b>3.1</b>	<b>SAFETY INFORMATION</b>	<b>26</b>
<b>3.2</b>	<b>FUEL</b>	<b>27</b>
3.2.1	The use of manufactured logs	28
3.2.2	Simple wood moisture test	29
<b>3.3</b>	<b>NOTES ABOUT FIRST FIRING</b>	<b>29</b>
<b>3.4</b>	<b>LIGHTING A FIRE</b>	<b>29</b>
<b>3.5</b>	<b>MAINTAINING THE FIRE</b>	<b>31</b>
<b>3.6</b>	<b>BLOWER OPERATION</b>	<b>31</b>
<b>4.</b>	<b>MAINTENANCE</b>	<b>32</b>
<b>4.1</b>	<b>CLEANING AND PAINTING YOUR STOVE</b>	<b>32</b>
<b>4.2</b>	<b>GLASS</b>	<b>32</b>
<b>4.3</b>	<b>GASKETING</b>	<b>33</b>
<b>4.4</b>	<b>ASH REMOVAL USING THE ASH DRAWER</b>	<b>33</b>
<b>4.5</b>	<b>CHIMNEY (FLUE) CLEANING</b>	<b>34</b>
<b>4.6</b>	<b>BAFFLE INSTALLATION</b>	<b>35</b>
4.6.1	Baffle installation for Solution 1.8 model	35
4.6.2	Baffle installation for Solution 2.9 model	36
<b>4.7</b>	<b>SECONDARY AIR TUBE REPLACEMENT</b>	<b>37</b>
<b>5.</b>	<b>SPECIFICATIONS</b>	<b>38</b>
<b>5.1</b>	<b>SOLUTION 1.8</b>	<b>38</b>
<b>5.2</b>	<b>SOLUTION 2.9</b>	<b>39</b>
	<b>ENERZONE LIMITED LIFETIME WARRANTY</b>	<b>40</b>

# 1. INSTALLATION

When installed and operated as described in these instructions, the E.P.A Enerzone wood stove is suitable for use as a freestanding wood stove in residential installations. The E.P.A Enerzone wood stove is not intended for installation in a bedroom.

In Canada, the CSA B365 Installation Code for Solid Fuel Burning Appliances and Equipment and the CSA C22.1 Canadian National Electrical Code are to be followed in the absence of local code requirements. In the USA, the ANSI NFPA 70 National Electrical Code and NFPA 211 Standard for Chimneys, Fireplaces, Vents and Solid Fuel-Burning Appliances are to be followed in the absence of local code requirements.

In addition to the national installation and/or local building codes, fire officials (or other authorities having jurisdiction) should be contacted to determine what restrictions and installation requirements might apply locally.

Only Solution 1.8 model is mobile home approved. Refer to the mobile home installation section for details.

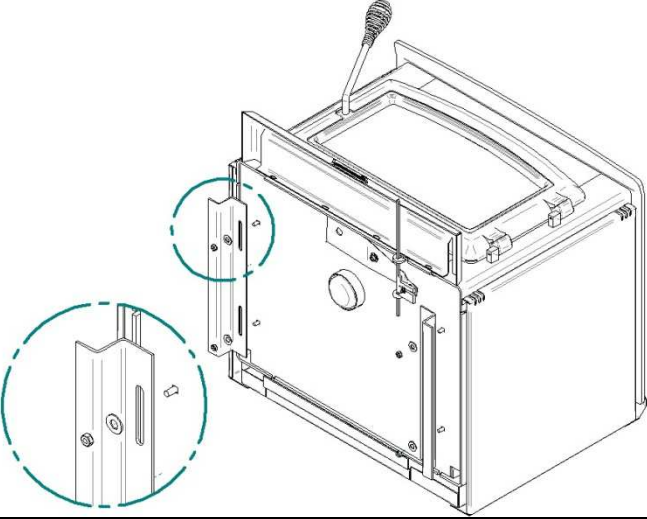
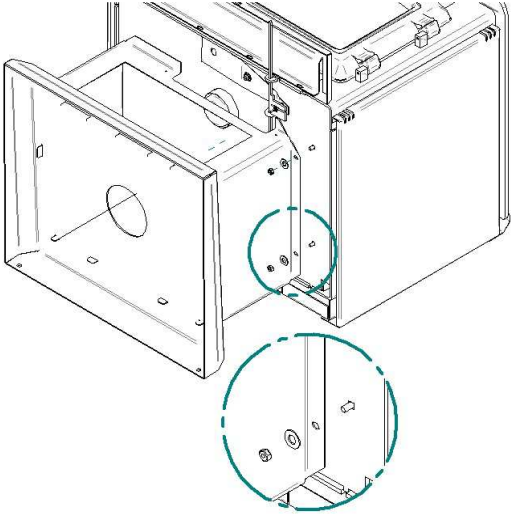
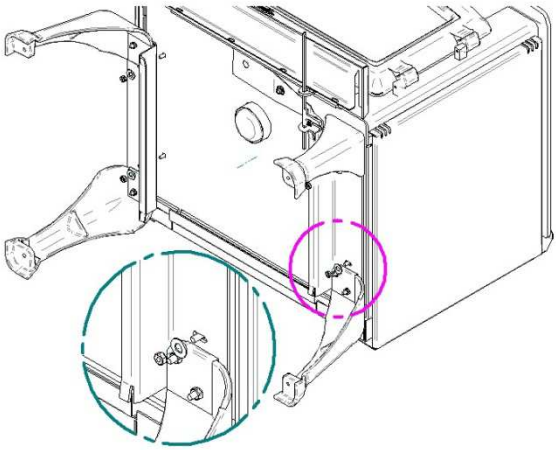
## 1.1 GENERAL INSTALLATION

### **CAUTION:**

- MIXING OF APPLIANCE OR FLUE SYSTEM COMPONENTS FROM DIFFERENT SOURCES OR MODIFYING THE DIMENSIONAL SPECIFICATION OF COMPONENTS MAY RESULT IN HAZARDOUS CONDITIONS. WHERE SUCH ACTION IS CONSIDERED, THE MANUFACTURER SHOULD BE CONSULTED IN THE FIRST INSTANCE.
- DO NOT CONNECT THIS UNIT TO ANY AIR DISTRIBUTION SYSTEM.
- CRACKED AND BROKEN COMPONENTS, e.g. GLASS PANELS OR CERAMIC TILES, MAY RENDER THIS INSTALLATION UNSAFE.
- A SOURCE OF FRESH AIR INTO THE ROOM OR SPACE HEATED SHALL BE PROVIDED WHEN REQUIRED.
- INSTALL A SMOKE DETECTOR IN THE ROOM WHERE THE STOVE IS LOCATED
- CONNECT THE STOVE ONLY TO A LINED MASONRY CHIMNEY CONFORMING TO NATIONAL AND LOCAL BUILDING CODES FOR USE WITH SOLID FUEL, OR TO A LISTED FACTORY BUILT CHIMNEY SUITABLE FOR USE WITH SOLID FUEL.

### 1.1.1 Pedestal or leg kit assembly

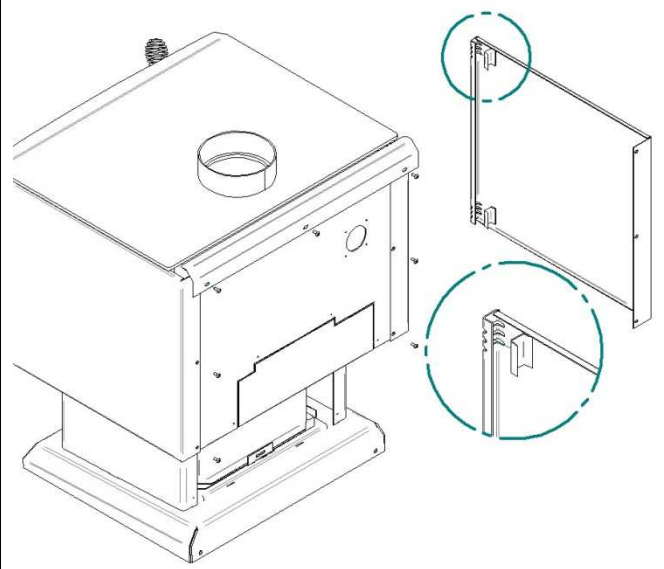
We suggest assembling the leg kit or pedestal before positioning the stove. See table 1.1.1 below:

	<p>1- Unscrew the 4 bolts in order to remove the 2 steel supports. Dispose of the two steel supports. They are no longer required.</p> <p><b>Note:</b> Parts may vary slightly from one model to another but the assembly procedure remains the same.</p>
 <p>2 (A) - Fix the pedestal base using the 4 bolts and washers removed in the previous step.</p>	 <p>2 (B) - Fix the 2 leg supports using the 4 bolts and washers removed in the previous step.</p>

**Table 1.1.1 Pedestal or leg kit assembly**

### 1.1.2 Installation of the decorative u-shaped inserts

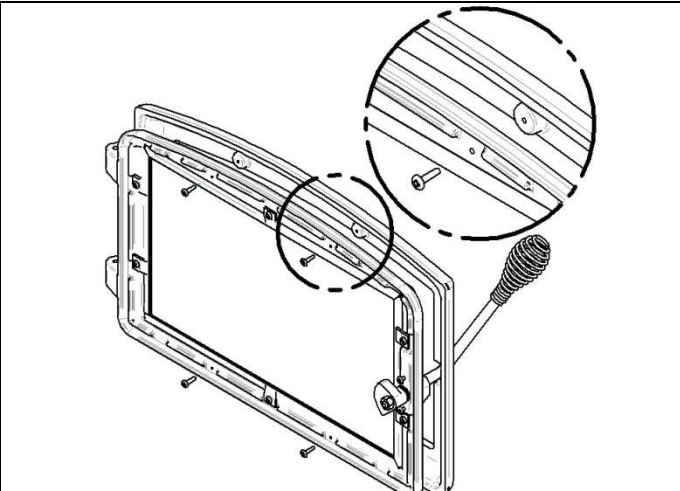
Your freestanding Enerzone wood stove is equipped with decorative u-shaped inserts. See table 1.1.2 below for installation instructions:

	<ol style="list-style-type: none"><li>1- Remove the 7 screws that retain the side panels and the rear heat shield deflector.</li><li>2- Remove the side panels and clip the U-shaped inserts (choose between gold or nickel finish) at the top and bottom of each panel.</li><li>3- Screw the side panels and heat shield deflector back into place.</li></ol>
---	--

**Table 1.1.2 Installation of the decorative u-shaped inserts**

### 1.1.3 Door overlay installation

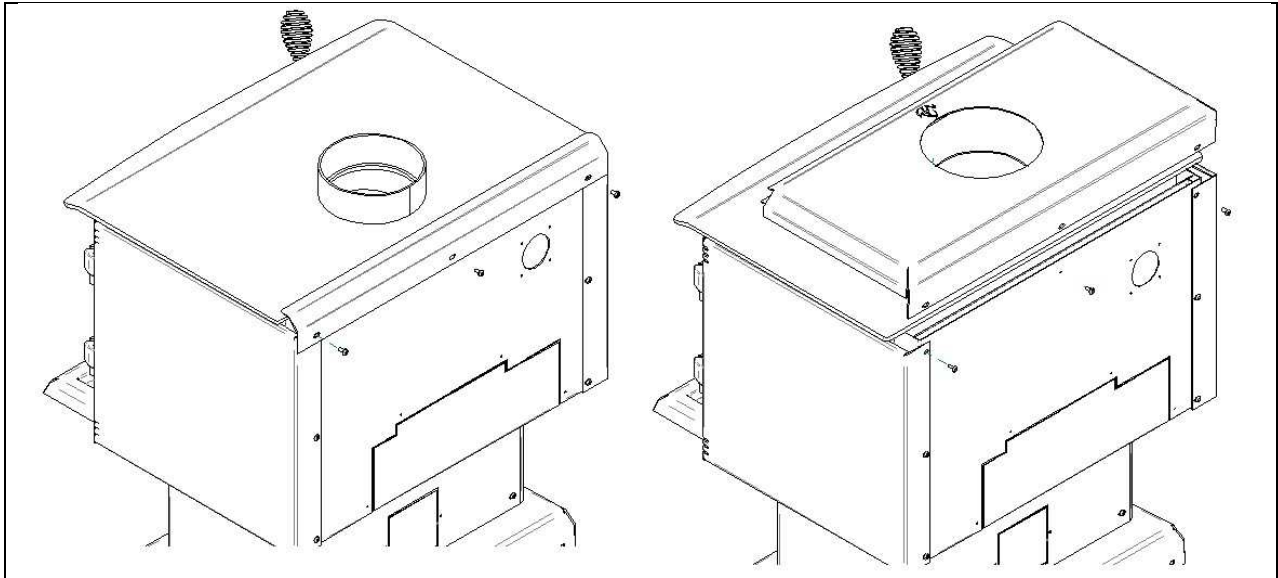
In order to complete the assembly of your freestanding Enerzone wood stove, you need to install the door overlay. See table 1.1.3 below for installation instructions:

	<ol style="list-style-type: none"><li>1- Position the overlay on the door frame and fix it in place from behind using the 4 screws.</li></ol> <p><b>Note:</b> It is not necessary to remove the glass or any other component to install the overlay.</p>
---	--

**Table 1.1.3 Door overlay installation**

### 1.1.4 Optional air mate installation

Most freestanding Enerzone wood stoves can be equipped with an optional air mate. This device accumulates heat and increases the air flow. See tale1.1.4 below for installation instructions:



- 1- Remove the 3 screws holding the rear eat shield deflector.
- 2- Position the air mate on top of the stove and fix it in place using the 3 screws removed in step #1.

**Table 1.1.4 Optional air mate installation**

## 1.2 POSITIONING THE STOVE

It is very important to position the wood stove in an area that will favour the most efficient heat distribution throughout the house. The stove should therefore be installed in the room where the most time is spent, and in the most spacious room possible. Recall that wood stoves produce radiating heat, the heat we feel when we are close to a wood stove. A wood stove also functions by convection, which is through the displacement of hot air accelerated upwards and its replacement with cooler air at the floor level. The stove's convection effect is facilitated by the installation of a blower.

## 1.3 CLEARANCES TO COMBUSTIBLES AND FLOOR PROTECTOR

To install your appliance correctly, it is extremely important to respect all clearances to any combustibles as indicated on your stove's certification label.

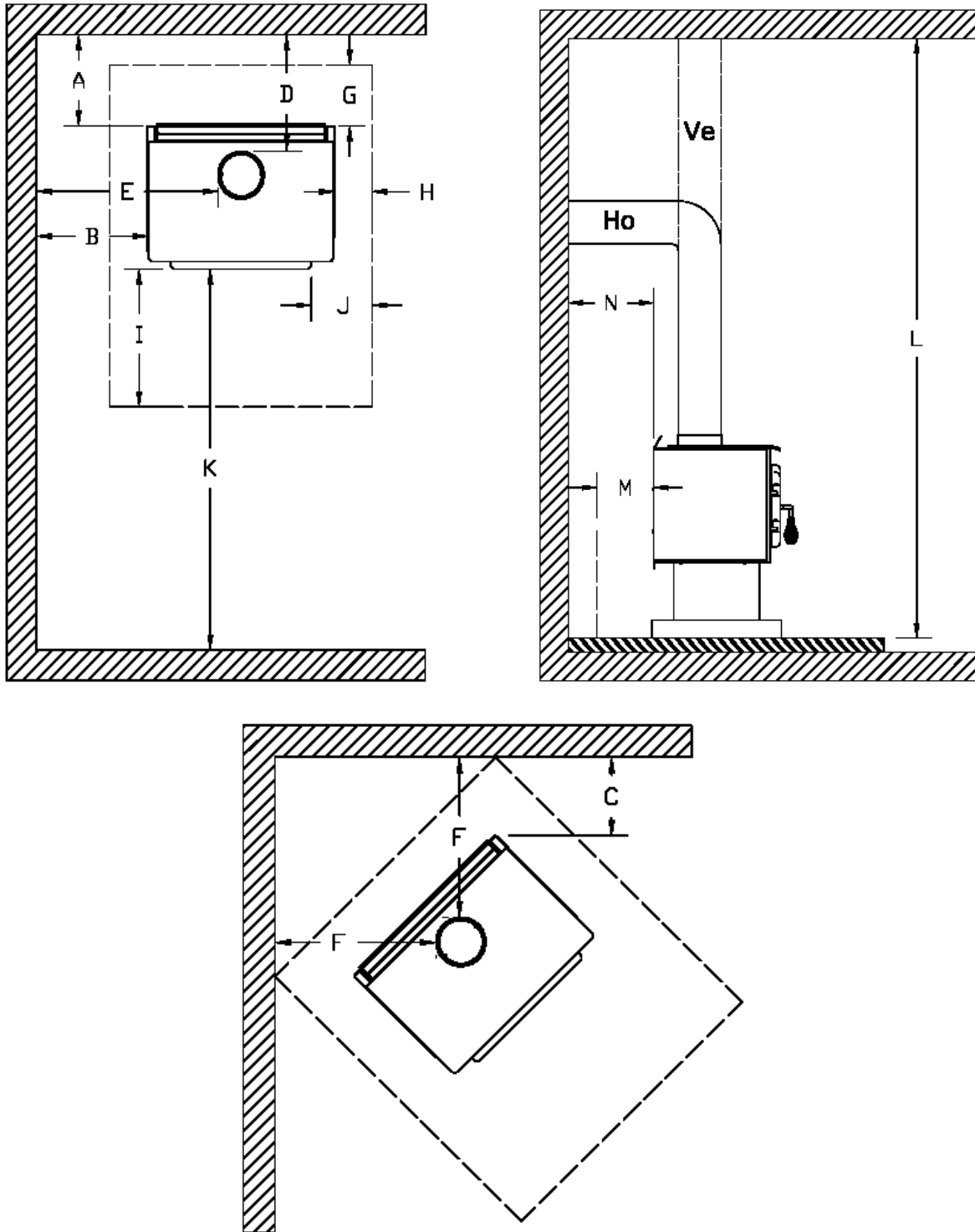
### Clearances to combustible materials

(see figure 1.3 to match each letter to a clearance)

	<b>CLEARANCES (SINGLE WALL PIPE) CANADA / USA</b>							
<b>MODEL</b>	<b>A</b>	<b>B</b>	<b>C</b>	<b>D</b>	<b>E</b>	<b>F</b>	<b>K</b>	<b>L</b>
Solution 1.8	14" (356 mm)	12" (305 mm)	7" (178 mm)	18" (457 mm)	22" (559 mm)	18" (457 mm)	48" (1220 mm)	84" (213 cm)
Solution 2.9	14"/10" (356/254 mm)	14" (356 mm)	7"/6" (178/152 mm)	18"/14" (457/356 mm)	23" (584 mm)	18"/17" (457/432 mm)	48" (1220 mm)	84" (213 cm)

	<b>CLEARANCES (DOUBLE WALL PIPE) CANADA / USA</b>							
<b>MODEL</b>	<b>A</b>	<b>B</b>	<b>C</b>	<b>D</b>	<b>E</b>	<b>F</b>	<b>K</b>	<b>L</b>
Solution 1.8	6" (152 mm)	11" (279 mm)	5" (127 mm)	10" (254 mm)	21" (533 mm)	16" (406 mm)	48" (1220 mm)	84" (213 cm)
Solution 2.9	6" (152 mm)	12" (305 mm)	6" (152 mm)	10" (254 mm)	21" (533 mm)	17" (432 mm)	48" (1220 mm)	84" (213 cm)





**FIGURE 1.3** Clearances to combustible materials and floor protection

## **Floor protector**

If the stove is to be installed on top of a combustible floor, it must be guarded by a non combustible material as shown on figure 1.3 (see the dotted line area).

	<b>FLOOR PROTECTOR*</b>	
	<b>CANADA</b>	<b>USA</b>
<b>G</b>	8'' (203 mm) – Note 1	N/A (Canada only)
<b>H</b>	8'' (203 mm)	N/A (Canada only)
<b>I</b>	18'' (457 mm) From door opening	16'' (406 mm) From door opening
<b>J</b>	N/A (USA only)	8'' (203 mm)
<b>M</b>	8'' (203 mm)	N/A (Canada only)
<b>N</b>	N/A (USA only)	Note 2

*\*Steel with a minimum thickness of 0.015'' (0.38 mm) or ceramic tiles sealed together with grout. No protection is required if the unit is installed on a non-combustible floor (ex: concrete).*

**Note 1:** The floor protection at the back of the stove is limited to the stove's required clearance if such clearance is smaller than 8 inches (203 mm).

**Note 2:** Only required under the horizontal section of the connector. Must exceed each side of the connector by at least 2 inches (51 mm).

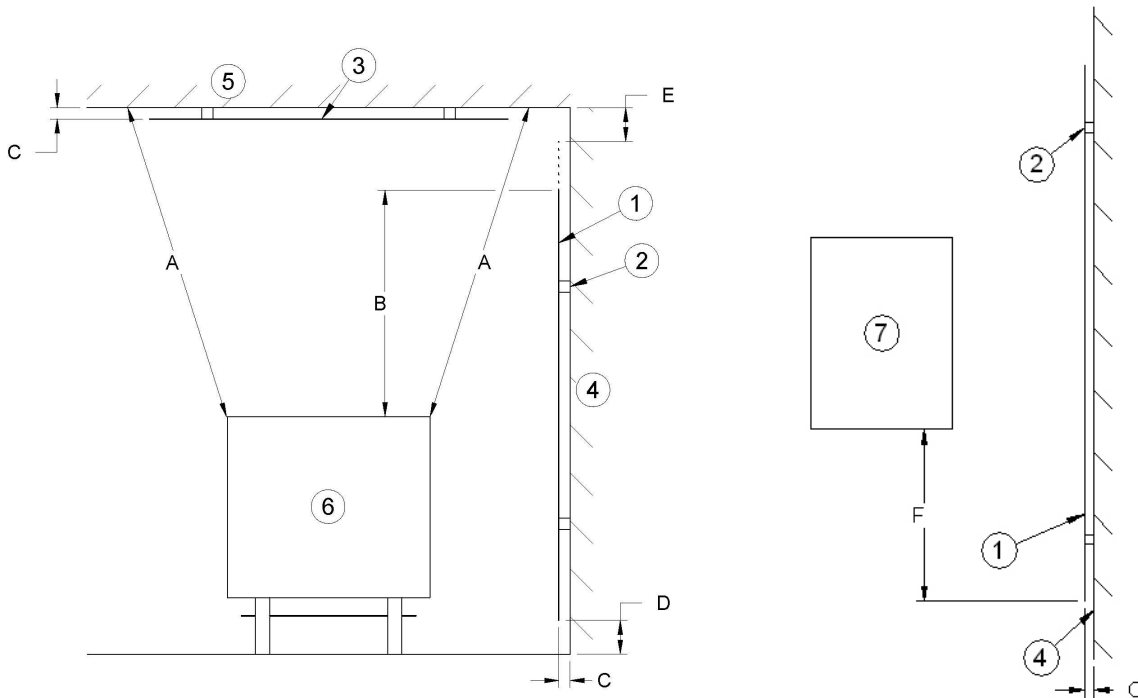
## **Reduced clearances using shielding**

You may decrease the clearances by installing heat radiation shields between the walls or the ceiling and the stove. These heat radiation shields must be installed permanently, and can include sheet metal, a rigid non-combustible sheet or a masonry wall.

Clearances of not less than 1" (25 mm) and not more than 3" (76 mm) between the bottom of the shield and the floor and not less than 3" (76 mm) between the top of the shield and the ceiling must be respected to allow vertical air circulation behind the shield. The shield must extend 20" (500 mm) above the stove top and 18" (450mm) to each side of the stove (*see graphic 1*).

Following the installation of such a heat radiation shield, the clearances mentioned on the stove certification plate may be reduced as stated in the following table.

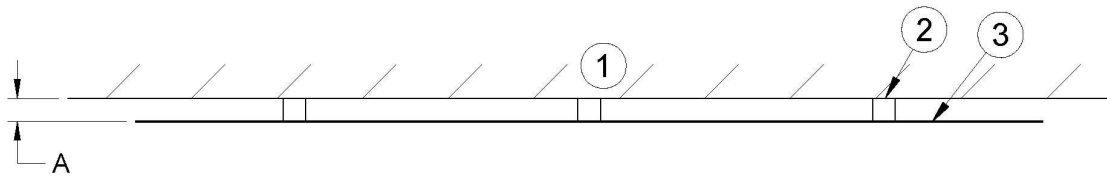
TYPE OF PROTECTION	Reducing Clearances With Shielding	
	Sides and Rear/Back	Top
Sheet metal, a minimum of 0,024" (0,61mm) spaced out at least 1" (25mm) by non-combustible spacers (see <i>graphic 2</i> ).	67%	50%
Ceramic tiles, or an equivalent non-combustible material on fire-proof supports spaced out at least 1" (25 mm) by non-combustible spacers (see <i>graphic 3</i> ).	50%	33%
Ceramic tiles, or an equivalent non-combustible material on fire-proof supports with a minimum of 0,024" (0,61 mm) sheet metal backing spaced out at least 1" (25 mm) by non-combustible spacers (see <i>graphic 4</i> ).	67%	50%
Brick spaced out at least 1" (25 mm) by non-combustible spacers (see <i>graphic 5</i> ).	50%	N/A
Brick with a minimum of 0,024" (0,61 mm) sheet metal backing spaced out at least 1" (25 mm) by non-combustible spacers (see <i>graphic 6</i> ).	67%	N/A



1.1.4.1 Graphic 1

- A- Minimum clearance required between the appliance and an unshielded combustible ceiling.
- B- 20 in. (500 mm) minimum;
- C- 1 in. (25 mm) minimum;
- D- Between 1 in. and 3 in. (25 mm and 75 mm);
- E- 3 in.(75 mm) minimum;
- F- 18 in. (457 mm) minimum.

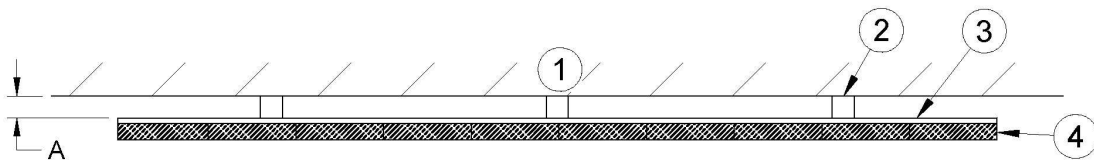
- 1- Shielding;
- 2- Non-combustible spacers;
- 3- Ceiling protector;
- 4- Combustible wall;
- 5- Ceiling;
- 6- Appliance (side view);
- 7- Appliance (top view).



**1.1.4.2 Graphic 2**

- A- 1 in. (25 mm) minimum;

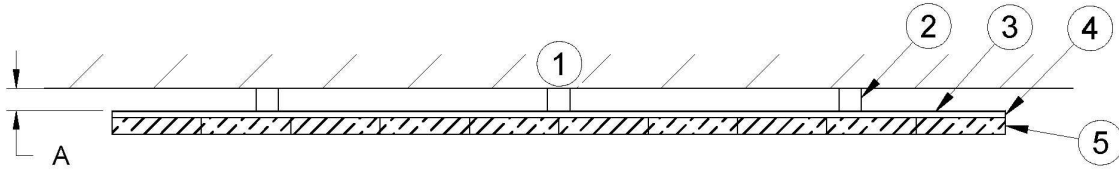
- 1- Combustible wall;
- 2- Non-combustible spacers;
- 3- 0.02 in (0.61mm) sheet metal.



**Graphic 3**

- A- 1 in. (25 mm) minimum;

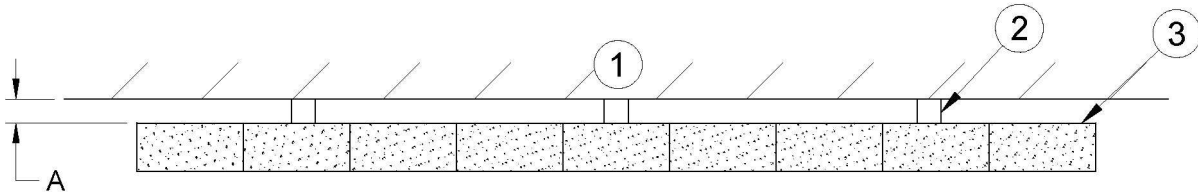
- 1- Combustible wall;
- 2- Non-combustible spacers;
- 3- Non-combustible support;
- 4- Ceramic tile or non-combustible material.



**Graphic 4**

A- 1 in. (25 mm) minimum;

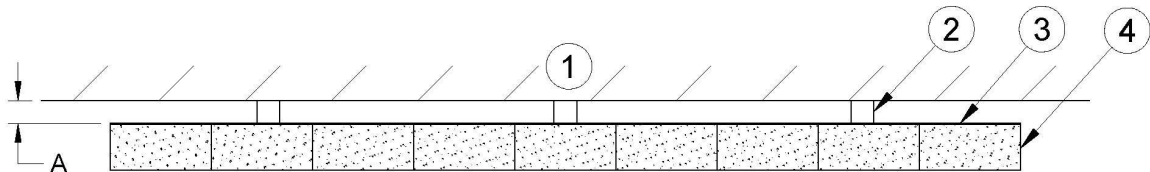
- 1- Combustible wall;
- 2- Non-combustible spacer;
- 3- 0.024 in (0.61 mm) thick sheet metal;
- 4- Non-combustible support;
- 5- Ceramic tile or non-combustible material.



**Graphic 5**

A- 1 in. (25 mm) minimum;

- 1- Combustible wall;
- 2- Non-combustible spacers;
- 3- Brick.



**Graphic 6**

A- 1 in. (25 mm) minimum;

- 1- Combustible wall;
- 2- Non-combustible spacers;
- 3- 0.024 in (0.61 mm) thick sheet metal;
- 4- Brick.

## 2. CHIMNEY (FLUE SYSTEM)

### 2.1 DEFINITIONS

For clarity, the following definitions should be used with respect to these instructions:

- A ***chimney system*** consists of a ***connector*** off the top of the stove, and a ***chimney***, which attaches to the connector and terminates outside the house.
- A ***chimney*** can be a ***masonry chimney*** (of masonry construction with an inside liner), or a ***factory built chimney***.
- A ***factory built chimney*** can be a ***double walled chimney*** (two concentric pipes with insulation - sometimes referred to as an insulated ***solid pack***) or an ***air cooled chimney*** (three concentric pipes, with insulation between the first and second pipes, and air between the second and third pipes).
- A ***single walled*** connector is a single pipe.
- A ***double walled*** connector has two concentric pipes, no insulation, and is an ***air cooled*** connector.

### 2.2 CHIMNEY

#### CAUTION:

- DO NOT fill any framed space around the factory-built chimney with insulation or any other material. Insulation placed in this area could cause adjacent combustibles to overheat.
- Do not use makeshift compromises during installation as they may be safety hazards, and a fire could result.
- Do not connect this unit to a chimney system serving another appliance.
- Do not cut rafters or ceiling joists without first consulting a building official to ensure structural integrity is not compromised.

Your wood stove may be hooked up with a factory built or masonry chimney. If you are using a factory built chimney, it must comply with UL103 (USA) or ULCS629 (Canada) standards. It must therefore be a 6" (152mm) HT Type (2100°F) chimney. It is extremely important that it be installed according to the manufacturer's specifications. The manufacturers' installation instructions and specified clearances should always be followed in accordance with local and national installation codes. In Canada the CSA B365 and the CSA C22.1 installation codes are to be followed. In the USA the ANSI NFPA 70 and ANSI NFPA 211 installation codes are to be followed.

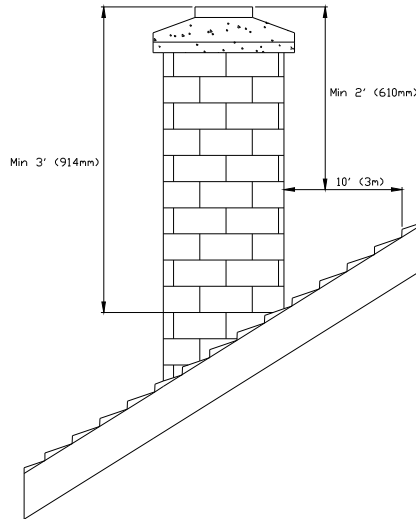
If you are using a masonry chimney, it is important that it be built in compliance with the specifications of the Building Code. It must be lined with fire clay bricks, or clay tiles, sealed together with fire cement, or have a listed solid fuel burning stainless steel liner. Round chimneys are the most efficient.

The interior diameter of the chimney should be identical to the stove's smoke exhaust. A chimney which is too small may cause draft problems, since it may not have the required volume to properly evacuate the quantity of smoke resulting from the combustion. A chimney which is too large may also cause draft problems. In fact, a large chimney will be harder to warm-up and may not reach high enough temperatures to create a proper draft effect. **Note that it is the chimney which creates the draft effect, not your stove. Your stove's performance is therefore directly dependent on an adequate draft from your chimney.**

The following recommendations may be useful for the installation of your chimney:

- Do not connect your stove to a chimney serving another appliance.
- The chimney must rise above the roof at least 3' (0.9 m) from the uppermost point of contact. See Figure 2.2.
- The chimney must exceed any part of the building or other obstruction within a 10' (3.04 m) distance by a height of at least 2' (0.6 m). See Figure 2.2.
- The minimum overall height of the chimney system, measured from the stove top to the exterior termination cap of the chimney should be at least 12' (3.66m). A chimney which is too short may lack the "tunnel effect" required to obtain a proper draft.
- Installation of an interior chimney is always preferable to an exterior chimney. Chimneys constructed outside of the home on an exterior wall should be avoided if possible, especially in colder climates. The gas which circulates into an interior chimney will cool more slowly, thus reducing the build-up of creosote and the risk of flue fires.
- All else being equal, cooler chimneys will have less draft than hotter ones. This problem will be amplified if the chimney is excessively long. A chimney which is excessively long may be very hard to warm-up due to its higher volume. A cool chimney may even down draft (reverse flow) due to the difficulty in heating it up to operating temperature while trying to evacuate the stack gases.

- If an exterior chimney is used, the best results will be obtained by using a connector vertically off the unit to the highest possible point before elbowing off horizontally to the exterior chimney. For efficiency and safety reasons the stove *must not* be installed with an insulated chimney connected directly to the appliance.
- Using a fire screen at the extremity of the chimney requires regular inspection in order to insure that it is not obstructed, thus blocking the draft. It should be cleaned when necessary.



**FIGURE 2.2 Minimum Height of the Chimney**

### **2.2.1 Step by step installation of your factory-built chimney**

The way to install your chimney may vary from one chimney manufacturer to another. For installation instructions, we advise you to consult your chimney manufacturer whose products are sold at many North American retailers of wood stoves and related heating accessories.



## Typical installation through the wall

### Wall support system

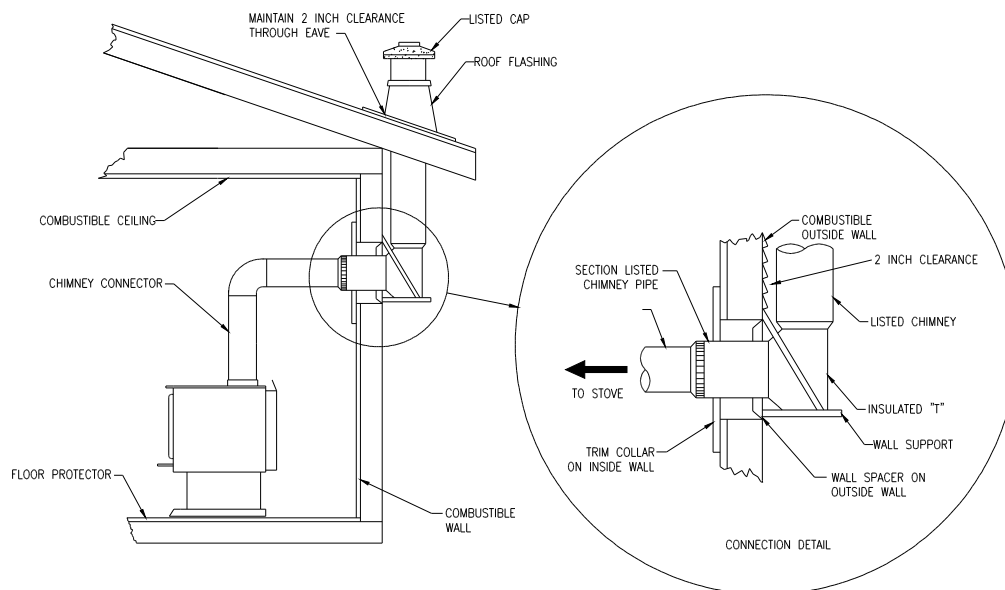
If your chimney must rise along an outside wall, you need to connect it to your stove through an adjacent wall. For this type of installation, the following items are normally required:

### Chimney

- Suitable lengths of chimney (enough to go up to your roof)
- An adjustable wall support
- A wall thimble
- An adequate number of wall bands (one for every 8 feet of chimney, excluding the roof portion)
- A stove pipe adapter
- One insulated tee & plug
- A roof flashing kit (if necessary)
- A chimney cap.
- Roof guys (if required)

### Stove pipe

- An adequate number of stove pipe sections.
- A 90° elbow



**FIGURE 2.2.1 (A) Typical installation through the wall**

## Typical installation through the ceiling

### Ceiling support system

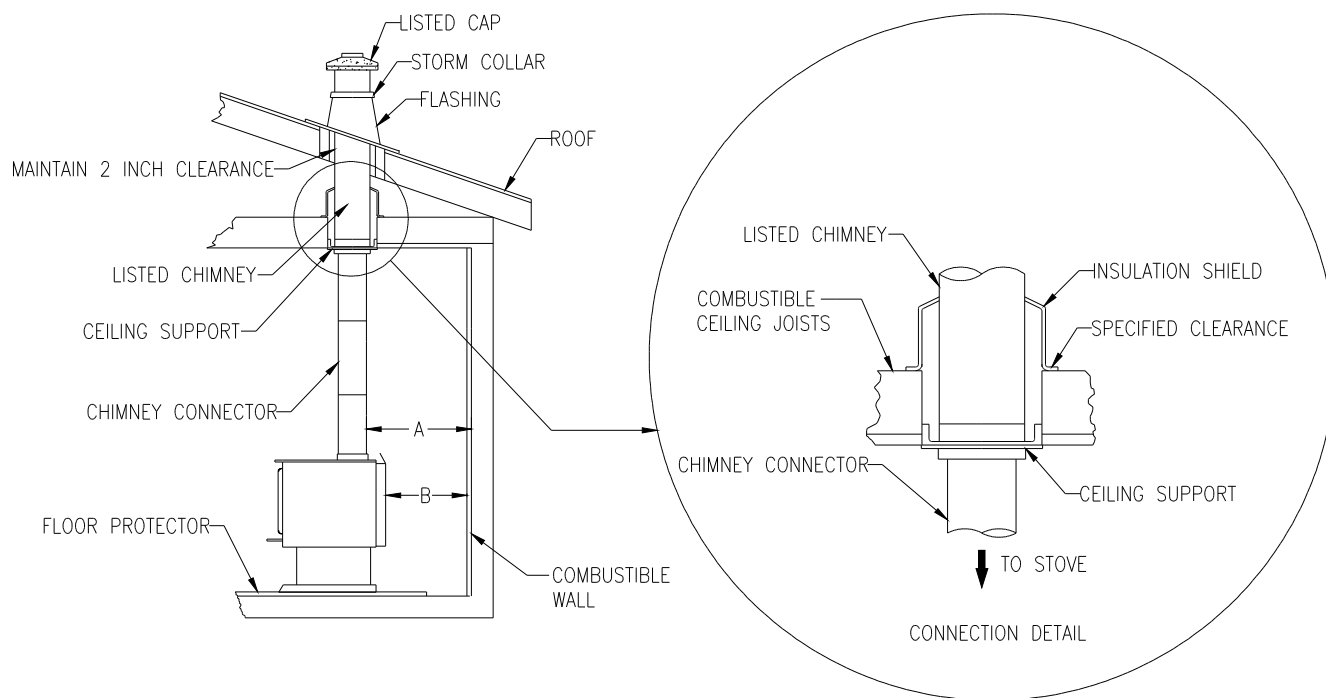
If your chimney must rise inside the house and go through the ceiling, you need to connect it to your stove at the ceiling level. For this type of installation, the following items are normally required:

### Chimney

- An adequate number of chimney sections (enough to go up to your roof)
- A ceiling support kit with stove pipe adapter
- An attic insulation shield
- A roof flashing kit
- A chimney cap
- Roof guys (if necessary)

### Stove pipe

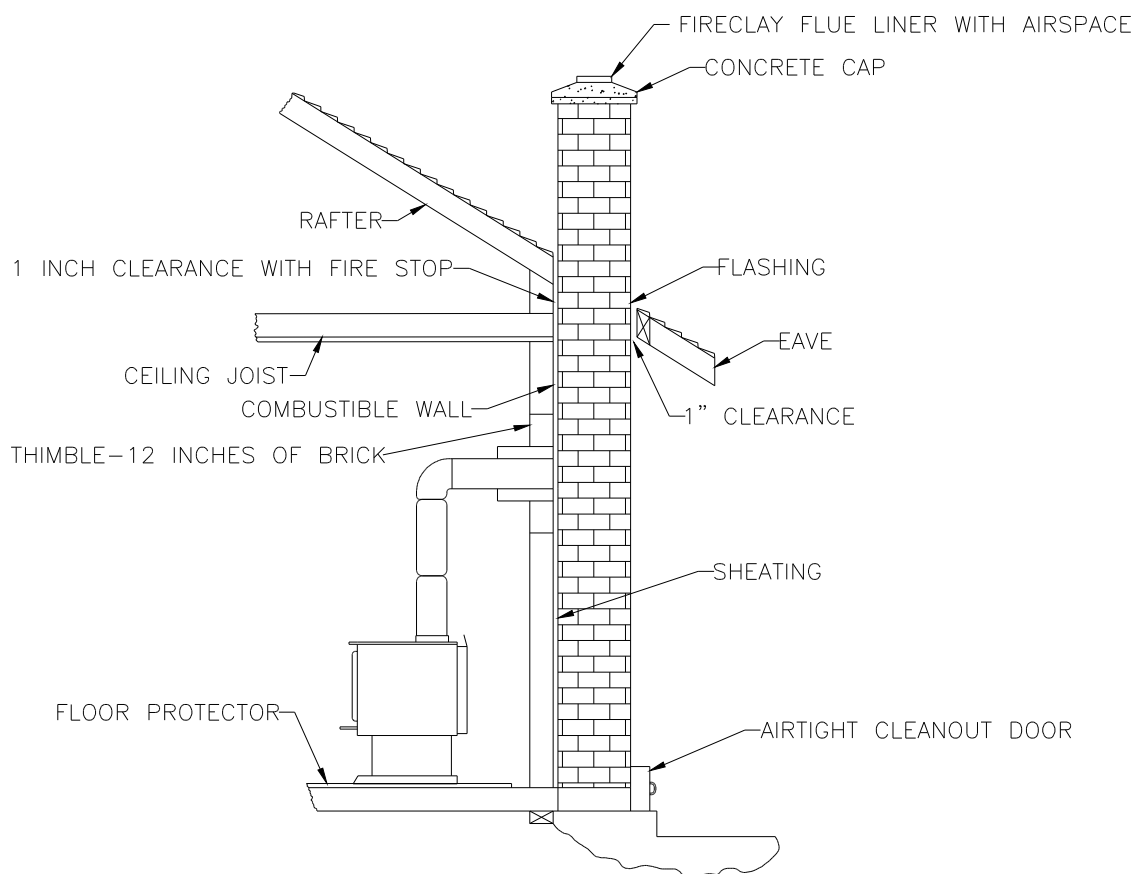
- Suitable lengths of stove pipe



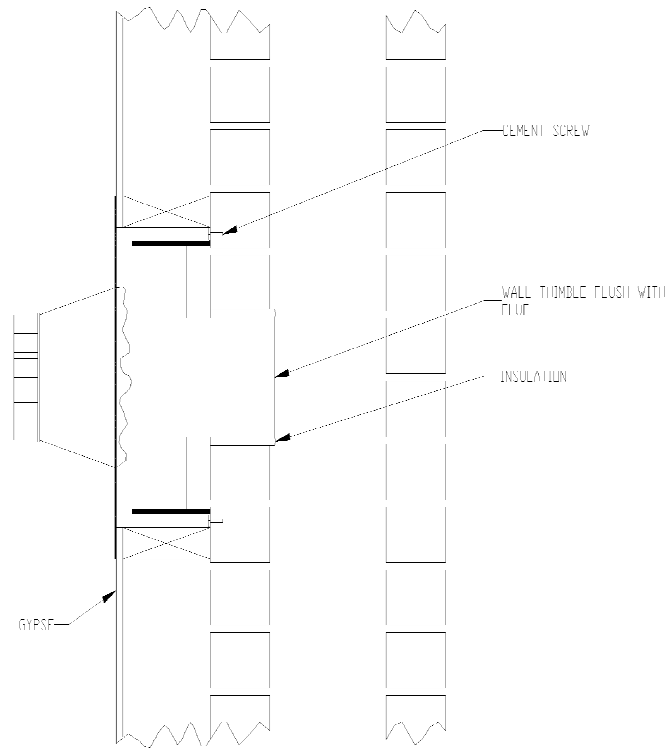
**FIGURE 2.2.1 (B) Typical Installation Through the Ceiling**

## 2.2.2 Typical installation through an existing masonry chimney

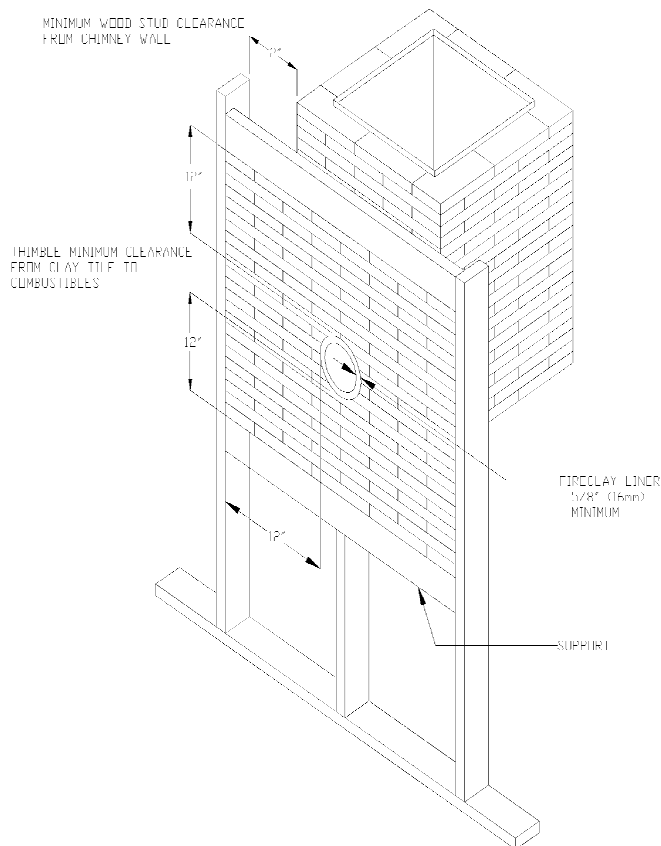
You can also install your stove using your existing masonry chimney. To do so, follow the guidelines below. You may want to use a factory-built thimble, or construct your own brick thimble. If you are using a masonry chimney, it is important that it be built in compliance with the specifications of the Building Code in your region. It must normally be lined with fire clay bricks, metal or clay tiles sealed together with fire cement. (Round flues are the most efficient).



**FIGURE 2.2.2 (A) Typical Installation Through an Existing Masonry Chimney**



**FIGURE 2.2.2 (B) Factory Built Thimble**



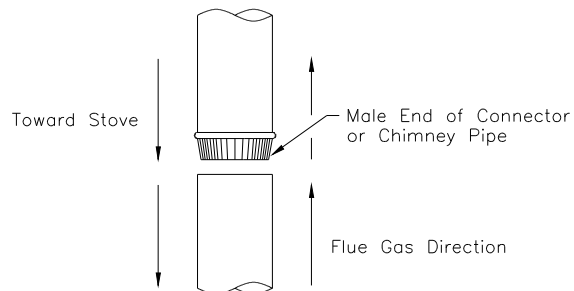
**FIGURE 2.2.2 (C) Brick Thimble**

## 2.3 CHIMNEY CONNECTOR

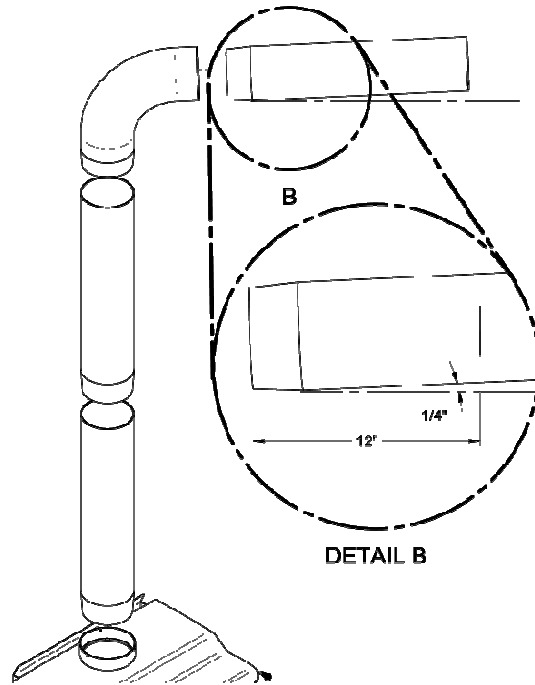
Your chimney connector (commonly called stove pipe) and chimney must have the same diameter as the stove's exhaust outlet. The stove pipe must be made of aluminized or cold roll steel with a minimum 24-gauge thickness (0.021" or 0.53 mm). It is strictly forbidden to use galvanized steel.

The following recommendations may be useful for the installation of your chimney connector:

- Your chimney connector should be assembled in such a way that the male end (crimped) faces down to prevent creosote dripping outside the joints. Attach each of the sections to one another with three equidistant metal screws. Also use three equidistant metal screws to attach the connector to the stove's exhaust collar. See Figure 2.3 (A) and Figure 2.3 (B).
- The pipe must be short and straight. All sections installed horizontally must slope at least ¼ inch per foot, with the upper end of the section toward the chimney. See Figure 2.3 Detail B.
- To insure a good draft, the total horizontal length of the connector should never exceed 8' to 10' (2.4 to 3.04 m). In the case of vertical installation, the total length of the connector can be much longer and connected without problem to the chimney at the ceiling level.
- There should never be more than two 90 degree elbows in the whole connector and chimney system. Never start with a 90° elbow. Always go up vertically for at least 2 feet from the flue spigot before using a 90° elbow.
- The connector must not pass through any combustible material, nor may it pass through a concealed space (such as an attic, roof space, or closet). If passing through a wall, ceiling, or into a masonry chimney, use either chimney components listed for that specific use, or means acceptable to local authorities having jurisdiction over the installation.
- Installation of a "barometric draft stabilizer" (fireplace register) on a connector is not recommended.

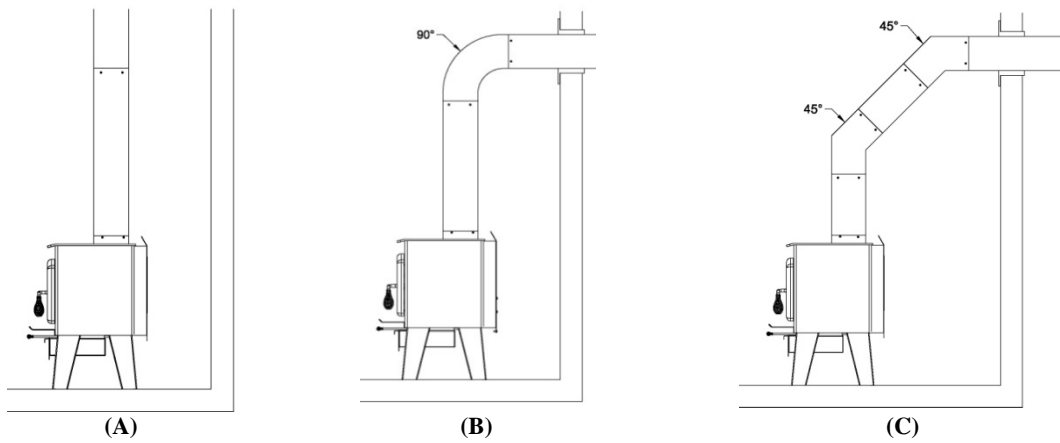


**FIGURE 2.3 (A) Connecting Sections**



**FIGURE 2.3 (B) Minimum Slope**

- The assembly should be as short and direct as possible between the stove and chimney (See figure 2.4 (A)). The use of two 45 degree elbows (See figure 2.4 (C)) is often preferable to a single 90 degree elbow (See figure 2.4 (B)) because less turbulence is created in the exhaust flow and they result in less horizontal run.



**FIGURE 2.4 The use of elbows**

## 2.4 DRAFT

Your E.P.A Drolet stove's performance will be optimized if it is installed with a chimney (flue) system that provides an adequate draft. The draft is the force that moves air from the appliance up through the chimney and is predominantly affected by the height and diameter of the chimney, as well as the stack temperatures of the stove. If you test the draft using a pressure gauge, the reading should be between .05 - .07 inches of water column (w.c.) at a medium-high fire. A draft measure of less than .03" w.c. will cause operational difficulties while too much draft (greater than .10" w.c.) will result in over-firing of the stove. This can result in excessive operating temperatures. In this case, the installation of elbows totaling no more than 180° (ex.: 2 x 30° elbows, 2 x 45° elbows or 2 x 90° elbows) can be installed to help reduce excessive draft. If the addition of elbows is not sufficient, a manual damper can be installed in the vertical flue pipe.

## 2.5 FRESH AIR INTAKE KIT

It is recommended to install 5" fresh air intake kit in the room where the stove is located or nearby. For Solution 2.9 and Solution 1.8, the fresh air intake kit (OA10500) is only available with the pedestal option. Solution 1.8 model is mobile home approved. For this type of installation, it's mandatory to use and install a fresh air intake kit connected directly to the stove's pedestal.

The following are signs that a fresh air intake kit may be required:

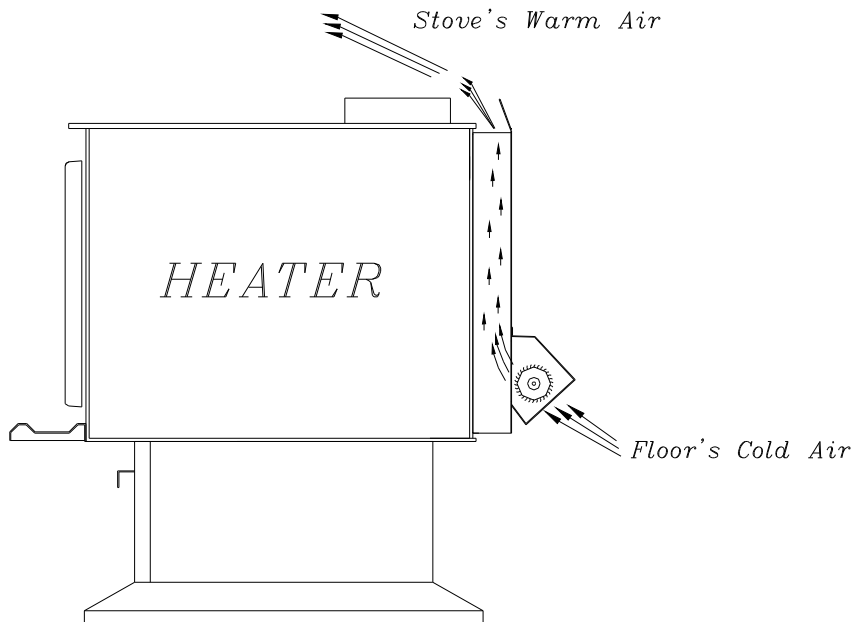
- Your stove does not draw steadily, smoke rollouts occur, wood burns poorly, or back-draft occurs whether or not there is combustion present.
- Existing fuel-fired equipment in the house, such as fireplaces or other heating appliances, smell, do not operate properly, suffer smoke rollouts when opened, or back-draft occurs whether or not there is combustion present.
- Opening a window slightly on a calm (windless) day alleviates any of the above symptoms.
- The house is equipped with a well-sealed vapour barrier and tight fitting windows and/or has any powered devices that exhaust house air.
- There is excessive condensation on windows in the winter.
- A ventilation system is installed in the house.

### **Warning for use in a MOBILE HOME:**

- DO NOT INSTALL IN A BEDROOM.
- THE STOVE MUST BE PROVIDED WITH OUTSIDE COMBUSTION AIR.
- THE STRUCTURAL INTEGRITY OF THE MANUFACTURED HOME FLOOR, WALL, CEILING / ROOF MUST BE MAINTAINED.
- THE STOVE MUST BE BOLTED TO THE FLOOR.
- INSTALL ACCORDING TO 24 CFR, PART 3280 (HUD)
- USE A CHIMNEY CERTIFIED FOR WOODBURNING UL 103 OU ULC S629, TYPE HT (2100°F).

## 2.6 THE ADVANTAGE OF INSTALLING A BLOWER

A blower can be installed at the back of your E.P.A Enerzone stove. This option is necessary if you wish to redistribute into a room the heat trapped at the back of your stove. By forcing hot air toward the front, the blower enables you to extend the radiation and convection power of your stove. You can purchase this option through your E.P.A Enerzone dealer. Make sure to specify the correct part number: AC01000. Installation instructions are supplied with the blower.





### 3. OPERATION

Keep these instructions for future reference.

#### **WARNING:**

- ANY MODIFICATION OF THE APPLIANCE THAT HAS NOT BEEN APPROVED IN WRITING BY THE TESTING AUTHORITY IS CONSIDERED AS BREACHING **CSA B365** (CANADA), AND **ANSI NFPA 211** (USA).
- DO NOT USE FLAMMABLE LIQUIDS OR AEROSOLS TO START OR REKINDLE THE FIRE.
- DO NOT USE FLAMMABLE LIQUIDS OR AEROSOLS IN THE VICINITY OF THIS APPLIANCE WHEN IT IS OPERATING.
- DO NOT STORE FUEL WITHIN HEATER INSTALLATION CLEARANCES.
- OPEN AIR CONTROL (AND DAMPER WHEN FITTED) BEFORE OPENING FIRING DOOR.
- THIS STOVE IS NOT DESIGNED TO BE USED WITH THE DOOR OPEN. THE DOOR MAY BE OPEN ONLY DURING LIGHTING PROCEDURES. NEVER LEAVE THE STOVE UNATTENDED WHEN THE DOOR IS OPEN.
- HOT WHILE IN OPERATION, KEEP CHILDREN, CLOTHING AND FURNITURE AWAY. CONTACT MAY CAUSE SKIN BURNS. **WEAR GLOVES TO OPERATE YOUR STOVE.**

#### **CAUTION**

- THIS APPLIANCE SHOULD BE MAINTAINED AND OPERATED AT ALL TIMES IN ACCORDANCE WITH THESE INSTRUCTIONS.
- THE USE OF SOME TYPES OF PRESERVATIVE-TREATED WOOD AS A FUEL CAN BE HAZARDOUS.
- DO NOT USE A GRATE IN THIS UNIT.

### 3.1 SAFETY INFORMATION

- These stoves are designed for safe operation *WHEN BURNING WOOD ONLY*. Altering or modifying the unit or installation without proper authorisation will void the certification, warranty, and safety listing, and may result in a safety hazard.
- For safety reasons, never leave the unit unattended with the door open or ajar. An open door, and especially a door partially open or cracked, if left for longer than required for good ignition can potentially result in unsafe chimney temperatures, and if left unattended, in hot embers or ignited fuel falling out of the unit. Prolonged door open operation is not necessary provided the unit has been properly installed and dry kindling is used to start the fire.
- Do not abuse the unit, either by over firing or by using wood or combustibles with salt content or harmful chemicals. Misuse is not covered by warranty.
- Even though your E.P.A Enerzone has been specifically designed and tested to prevent smoke spillage, always open the door slowly as this will minimise the likelihood of smoke spillage or a back draft of flame or smoke into the room.
- Never use gasoline type lantern fuel, kerosene, solvents, charcoal lighter fluid, or inflammable liquids to start or "refresh" a fire in the stove. Keep all such liquids well away from the stove while it is in use.
- All stove surfaces become very hot during operation. Care is needed, especially with children, to avoid contact with those surfaces.
- Do not elevate the fire by means of grates.
- **CAUTION: DO NOT OVER FIRE THIS HEATER.** Do not burn fuel in the stove at a rate higher than that which will cause the ember bed level to exceed half the door opening height. We strongly recommend that you purchase a chimney (flue) thermometer. There are two types of thermometers: probe thermometers and magnetic thermometers (the later is also called "stove top thermometer"). If you are using a probe thermometer, make sure that the temperature does not exceed 900°F (482°C). If you are using a magnetic thermometer, make sure that the temperature does not exceed 475°F (246°C). If the door handle of the stove becomes excessively hot to the touch, consider this to be an indication of over firing. Over firing can result in a safety hazard and can permanently damage the stove and chimney. This damage is not covered by the warranty.

- Although the ceramic glass is extremely durable under any normal use, a few precautions are required. Do not attempt to push logs further into the fire by using the door, as the glass may break if any solid object heavily contacts it.
- Never operate the stove with the door open, or cracked slightly open, except briefly during the lighting operation, and during refuelling. Leaving the door open continuously could seriously overheat the chimney and adjacent combustibles. Do not operate the stove if there is an abnormal air leakage into the stove, such as through deteriorated gaskets or cracked or broken glass. Do not operate the stove without a door gasket. Leakage can result in overheating, or in very airtight homes, could possibly cause smoking into the room. Smoke may contain carbon monoxide, which is poisonous, and in sufficient quantities, is a health hazard.

## 3.2 FUEL

Fuel for the stove must not be stored closer than the required clearances to combustibles (heat sensitive materials). **NEVER STORE WOOD IN THE ASH PAN COMPARTMENT.**

Your E.P.A Enerzone stove is designed to burn *WOOD ONLY*. Do not burn coal, charcoal, or trash in the unit. Highly flammable items such as trash may ignite creosote in the chimney (flue), resulting in a chimney fire. Never burn salt wood, beach wood, chemically treated wood, or wood removed from salt water, since the deposits left will deteriorate the firebox. Damage caused by chemicals or salt is not covered under warranty.

Seasoned cord wood is recommended. Wood should be air dried in a covered and ventilated area for a minimum of six months (one year or more is recommended). This reduces the moisture content of the wood, resulting in a better stove performance. Wood species with moisture content of 20% or less are ideal. Dry, seasoned cord wood, can be distinguished from green wood by the cracks at each end of the logs. Wet or green wood will tend to cause the fire to smoulder, producing large amounts of creosote. Creosote buildup could result in a chimney fire. This wood will also prove difficult to keep burning properly, and fires will tend to go out. Green wood produces very little heat, and sometimes causes customers to think that the stove does not work.

Decayed wood or low-density wood has very little energy content or heating value, and will not burn satisfactorily for long periods of time. An example of the energy values of some common wood fuels *found in North America* is given in the following table:

	Wood species	Energy yield (millions of BTU/cord)
High energy yield	Oak	29
	Sugar Maple	28
	Beech	26
	Yellow birch	25
	Ash	24
	Elm	23
Medium energy yield	Larch (Tamarack)	23
	Red Maple	23
	Douglas red fir	23
	Silver birch	22
	Alder	18
	Poplar	17
	Hemlock	17
Low energy yield	Spruce	17
	Pine	17
	Bass	16
	Fir	13

*Data provided by Energy, Mines and Resources – Canada*

**TABLE 3.2 Energy yield for wood species**

### 3.2.1 The use of manufactured logs

There are numerous types of manufactured logs sold on the market. You must be very careful with this type of product. Many brands of manufactured logs contain chemical additives. **DO NOT BURN ANY MANUFACTURED LOGS CONTAINING CHEMICAL ADDITIVES.** If you do, you may damage your stove and void the warranty. Logs containing chemical additives burn a lot hotter and were designed for decorative fireplaces. Decorative fireplaces generally have larger, cooler, and less air-tight fireboxes. Your E.P.A Enerzone stove, on the other hand, has a smaller, completely sealed firebox which attains much higher temperatures. It is therefore not designed to support excessive heat caused by the addition of chemicals in manufactured logs. Manufactured logs made of 100% wood residues do not cause any threat to your stove. You must however be careful. Manufactured logs typically release a much larger heat output over a short period of time. Therefore, you cannot place a large quantity of such logs into your stove, like you would with regular cord wood. Start with one log, and gradually increase the load to 3 or 4 logs and see how your stove reacts. Use a chimney (flue) thermometer and make sure that temperatures remain within the normal operating range.

### **3.2.2 Simple wood moisture test**

Add one large piece of wood to the top of an established fire. If it starts to burn on three sides within one minute, it is dry and seasoned and right for burning. If it turns black and starts to burn in about three minutes or more, it is damp. If it turns black and does not start burning until five minutes or more, it is green and wet. If it hisses at any time, the wood is soaked and will not burn until the excess of moisture is boiled away.

### **3.3 NOTES ABOUT FIRST FIRING**

The fresh paint on your stove needs to be cured to preserve its quality. Once the fuel load is properly ignited, only burn small fires in your stove for the first four hours of operation. Never open the air control more than necessary to achieve a medium burn rate. Make sure that there is enough air circulation while curing the stove. Open one or more windows. The odours can be smelled during the 3 or 4 first fires. Never start your stove outside.

### **3.4 LIGHTING A FIRE**

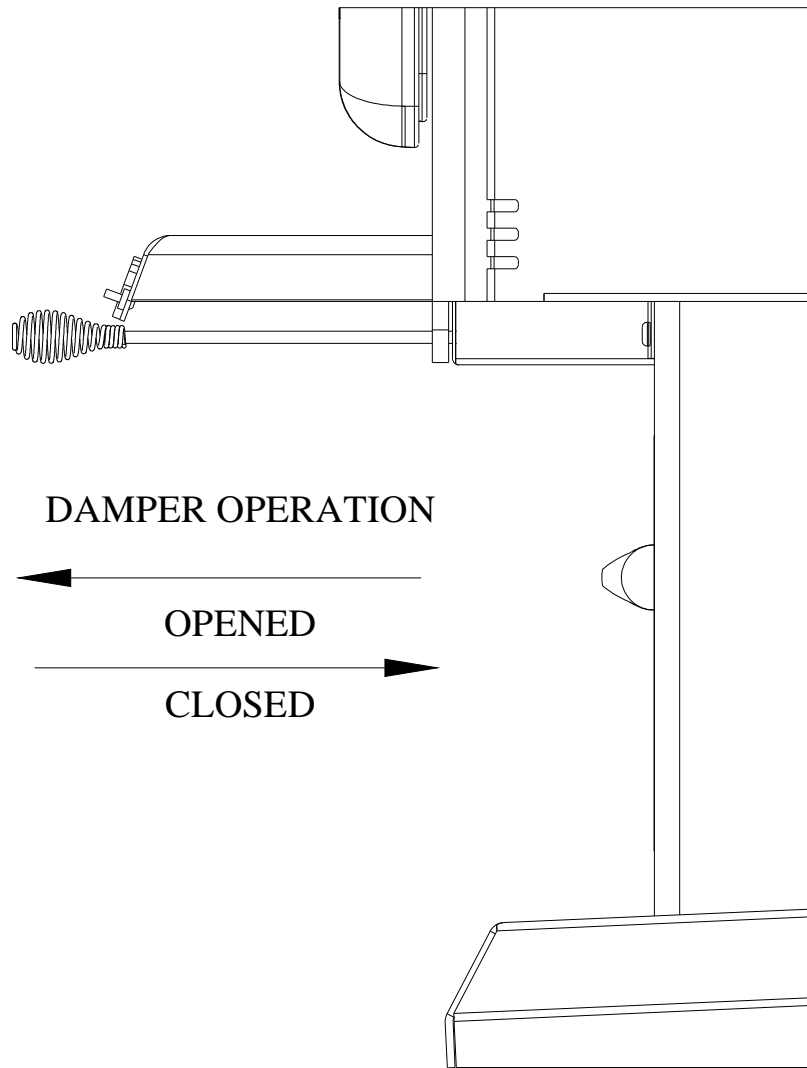
1. Place enough crumpled balls of newspaper or other paper into the stove to cover the bottom of the firebox.
2. Place small and dry kindling on the crumpled paper.
3. Place larger and dry kindling on top of the small kindling.
4. Open the air intake control fully. (see table 3.4)
5. Light a fire at the bottom of the crumpled paper and close the door. If the fire tends to go out momentarily, hold the door slightly ajar to activate the fire. As soon as the fire catches hold, close the door.
6. Ideally the large kindling should be burned until a thick bed of red embers is obtained. At that point, add cord wood fuel and continue to operate the draft control wide open until the fire is well established. Once the firebox is hot, the air control can be partially closed to adjust the intensity of the fire. Refer to table 3.4 to operate the air intake control properly.

Intensity	Draft Setting
Low	Push Control to end of travel.
Medium Low	Pull Control by 3/8" from closed position.
Medium High	Pull Control by 3/4" from closed position
High	Pull Control to end of travel.

**Table 3.4**

Closing the draft control down too soon will lower combustion efficiency, and may result in creosote build-up in the chimney (which could lead to a future chimney fire).

**CAUTION: THE ADJUSTMENT RANGE SHOULD NOT BE ALTERED FOR INCREASED FIRING FOR ANY REASON.**



**Figure 3.4**

### 3.5 MAINTAINING THE FIRE

Once the wood has been consumed (or partially consumed) and you have obtained a good bed of embers, you should reload the unit. In order to do so, open the air control to its maximum for approximately 15 seconds prior to opening the stove door. Then, proceed by opening the door very slowly. Open it by 2" to 4" (52 to 104 mm) for 10 to 15 seconds before opening it completely. This procedure will increase the draft and thus eliminate the smoke which is stagnant in a state of slow combustion in the stove. Then, bring the red embers to the front of the stove and reload the unit. **Depending on the type of wood you burn and the strength of the draft in your flue, you may have to leave the air control open to its maximum for more than 15 seconds to avoid smoke spillage before you reload the stove.**

Your E.P.A Enerzone stove will work best if a thick bed of hot embers is maintained in the bottom of the firebox and a minimum of two large pieces of seasoned fuel are added. Combustion efficiency is largely related to establishing a hot ember bed, and hot firebox temperatures. The quicker the stove and chimney (flue) get up to normal operating temperatures, the better. A small intense fire is preferred to a large smouldering fire, both to improve combustion efficiency and to reduce the amount of creosote build-up. The best performance will be obtained by adding relatively small amounts of fuel to a well established ember bed, and then operating with the air inlet control open long enough to achieve a hot fire. The wood should be placed with air in between individual pieces. Use a poker to make an air channel in the embers below the wood. This will allow air to flow under the wood for a more efficient burn.

In order to achieve an optimum efficiency from the Solution 1.8, we suggest that you operate it with the air control slightly open (approximately 10%). For the Solution 2.9 model, we suggest that you operate it with the air control completely closed. In both cases make sure that you have a good fire going and an adequate ember bed before you completely close the air control. Also, use a chimney thermometer if necessary. Closing the air control too soon will lower combustion efficiency and may cause the fire to die out.

In all Enerzone appliances the addition of a blower is highly recommended to maximize your unit's efficiency.

### 3.6 BLOWER OPERATION

If you have purchased and installed an optional blower, allow the stove to reach its operating temperature before turning it on (approximately one hour). The increased airflow from the blower will cool the firebox and affect the start-up combustion efficiency if the blower is turned on too quick.

***CAUTION: ENSURE THAT THE BLOWER'S POWER CORD IS NOT IN CONTACT WITH ANY SURFACE OF THE STOVE TO PREVENT ELECTRICAL SHOCK OR FIRE DAMAGE. DO NOT RUN THE POWER CORD BENEATH THE STOVE.***

## 4. MAINTENANCE

### 4.1 CLEANING AND PAINTING YOUR STOVE

Clean the stove frequently so that soot, ash, and creosote do not accumulate. Do not attempt to clean the stove when the unit is hot. Special care must be taken with plated surfaces in order to maintain the finish at its original brilliance. Do not use an abrasive cleaner which will scratch the paint or plated finish. Use only a soft and clean damp cloth.

If the paint becomes scratched or damaged, it is possible to give your wood stove a brand new look, by repainting it with a 650°C heat resistant paint. For this purpose, simply scrub the surface to be repainted with fine sand paper, clean it properly, and apply thin coats (2) of paint successively. To retrieve the original finish, use the paint supplied by the manufacturer.

### 4.2 GLASS

Under normal operation the glass is designed to stay clean. Glass cleaning may be required when burning damp wood and/or when burning slow fires. In general if the glass is not staying clean then the unit is being under fired. Dirty glass may be self cleaned by burning a hot fire (i.e. dry wood and opened draft controls) for a couple of hours. Good burning techniques will result in clean glass.

Hand clean the glass only when the fire is out and the stove is cold. A light film can usually be cleaned with paper towel and water. If heavy cleaning is required, a ceramic glass cleaner or polish is recommended, and should be rinsed off with water for best results.

To change the glass remove the 6 glass retainers and metal frame. Remove damaged glass and install the new one in place. Make sure you have a gasket around the replacement glass. Reinstall the metal frame and secure it with the glass retainers.

Do not abuse the door glass by striking, slamming or similar trauma. Do not operate the stove with the glass removed, cracked or broken.

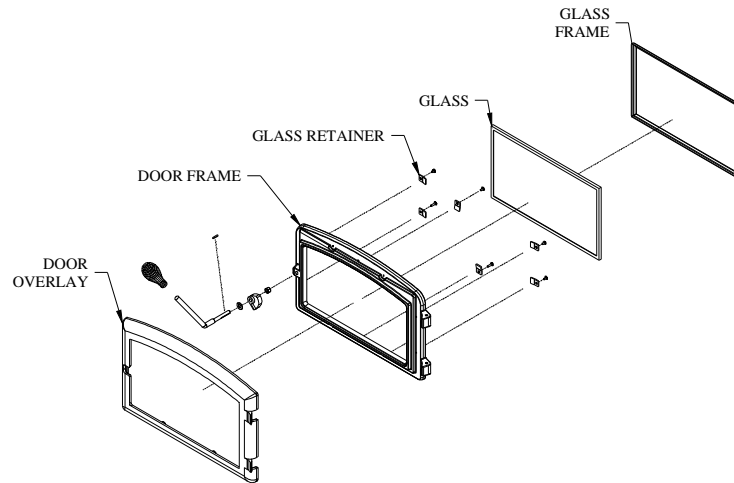
**The glass must be replaced by a genuine part only. Failure to follow instructions or use of different material may result in property damage, bodily injury, or even death.**



Glass specifications: Robax 5mm dimensions

Solution 1.8 17 3/32" x 9 13/16"

Solution 2.9 15 1/2" x 11 1/8"



### 4.3 GASKETING

It is recommended that you change the door gasket (which makes your stove door air tight) once a year, in order to insure good control over the combustion, maximum efficiency and security. To change the door gasket, simply remove the damaged one. Carefully clean the gasket groove, apply a high temperature silicone sold for this purpose, and install the new gasket. **Use only the genuine Enerzone gasket.** You may light up your stove again approximately 24 hours after having completed this operation.

### 4.4 ASH REMOVAL USING THE ASH DRAWER

**CAUTION: ASHES CAN START FIRES, EVEN AFTER SEVERAL DAYS OF INACTIVITY. NEVER DISPOSE OF ASHES IN A COMBUSTIBLE CONTAINER. REMOVE ASHES WHEN THE STOVE AND ASHES ARE COLD.**

Whenever the ashes get 3 – 4" (76 – 102 mm) deep in the firebox, they should be emptied into the ash drawer, using the following instructions:

- Make sure the fire is out, and the stove is cold.
- Lift the ash dump plug in the center of the firebox by hooking the poker through the loop on the cover and lifting up.
- Push the ashes through the hole and leave an ash bed of approximately 1" deep on the firebox bottom to help maintain a hot ember bed.
- Clear the ashes from the area where the ash dump plug normally sits so that it will properly seat against the opening edges. Tap it down with your poker to ensure proper seating.

- Ashes should be placed in a metal container with a tightly fitting lid. This closed container should be placed on a non-combustible floor or on the ground, well away from all combustible (heat sensitive) materials, pending final disposal.
- Cover the ash dump plug with the remaining ashes and continue operation of your stove as usual.
- If the ashes are disposed of by burial in soil or otherwise locally dispersed, they should be retained in the closed container until all cinders have thoroughly cooled. Do not place other waste materials in the metal ash container.
- If bright embers are glowing above the ash dump cap during a low or medium fire, air may be leaking past the ash plug. If this is happening, a possible over fire hazard exists. The stove should be shut down and allowed to cool. Properly seal the ash dump cap.

#### **4.5 CHIMNEY (FLUE) CLEANING**

Regular chimney (flue) maintenance, as well as good burning practices, is required to prevent chimney fires. When wood (especially green wood) is burned without adequate heat or air supply, it produces tar and other organic vapours (*smoke*), which combine with expelled moisture to form creosote. The creosote vapours condense in the relatively cool chimney of a slow-burning fire. As a result, creosote residues accumulate on the chimney. When ignited, this creosote makes an extremely hot fire which could be hazardous. Your E.P.A Enerzone stove has been designed to reduce the amount of creosote produced. Even so, the chimney and any chimney connector should be inspected at least once every two months during the heating season to determine if a creosote build-up has occurred. If creosote has accumulated, it should be removed to reduce the risk of a chimney fire. Call a professional chimney sweep, or go to your local E.P.A Enerzone dealer, purchase a chimney brush, and have the chimney cleaned.

Contact your local, municipal, state, or provincial fire authority for information on how to handle a chimney fire before there is any chance that it may happen.

## 4.6 BAFFLE INSTALLATION

### 4.6.1 Baffle installation for Solution 1.8 model

All firebrick and ceramic wool baffles must be properly in place for correct burning operation. Have any damaged firebricks replaced. Check the firebricks annually for damage and replace if they are broken or damaged. See figure 4.6.2 (B) for the firebrick layout.

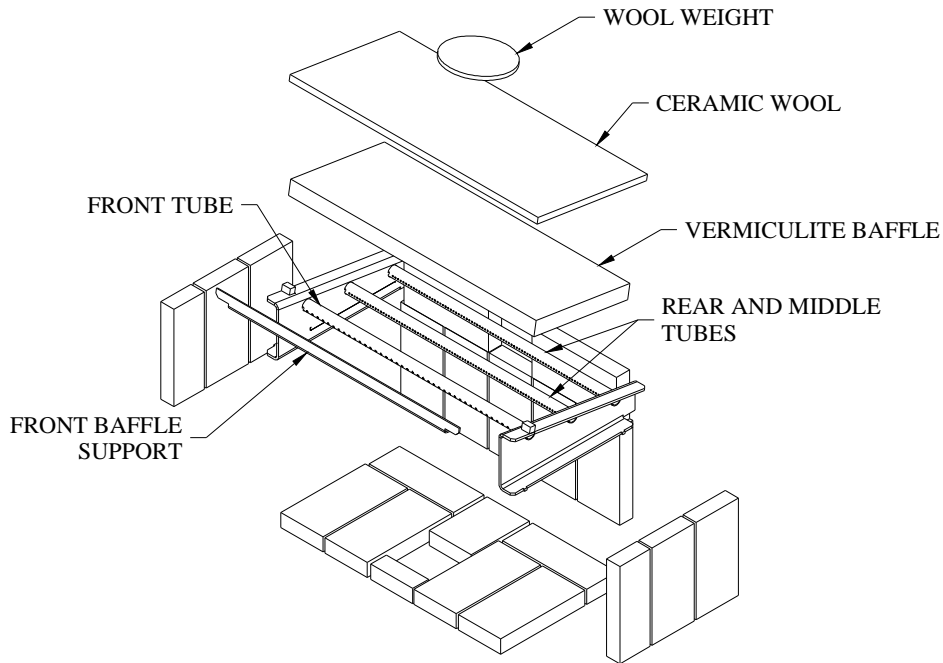


Figure 4.6.2 (A) - Baffle installation for Solution 1.8 model

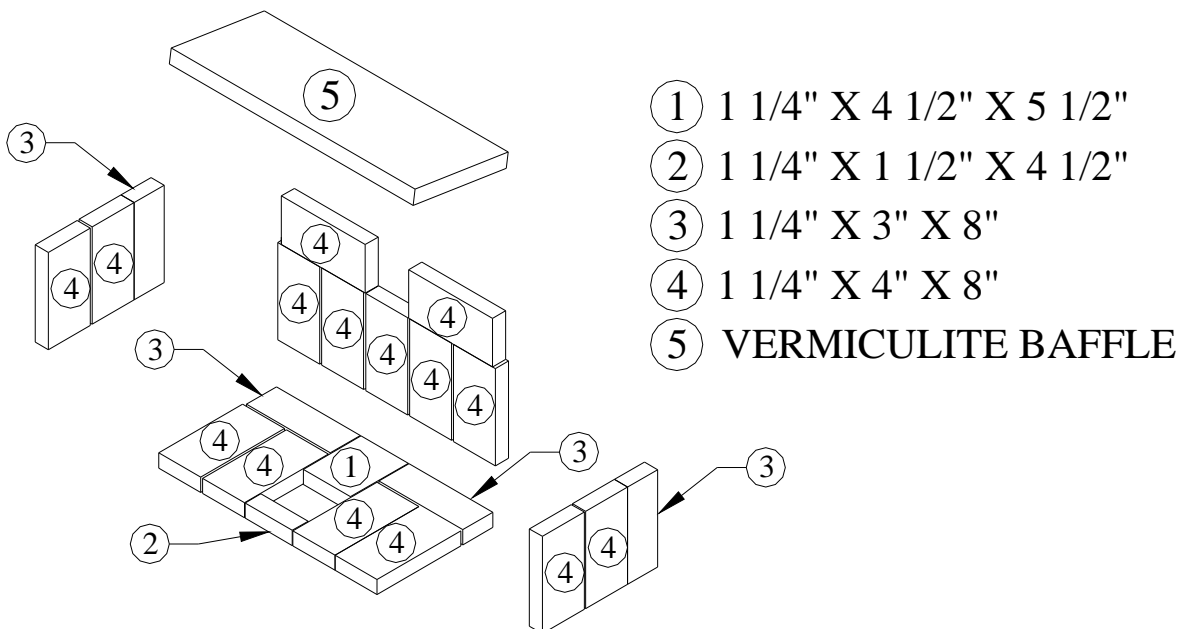
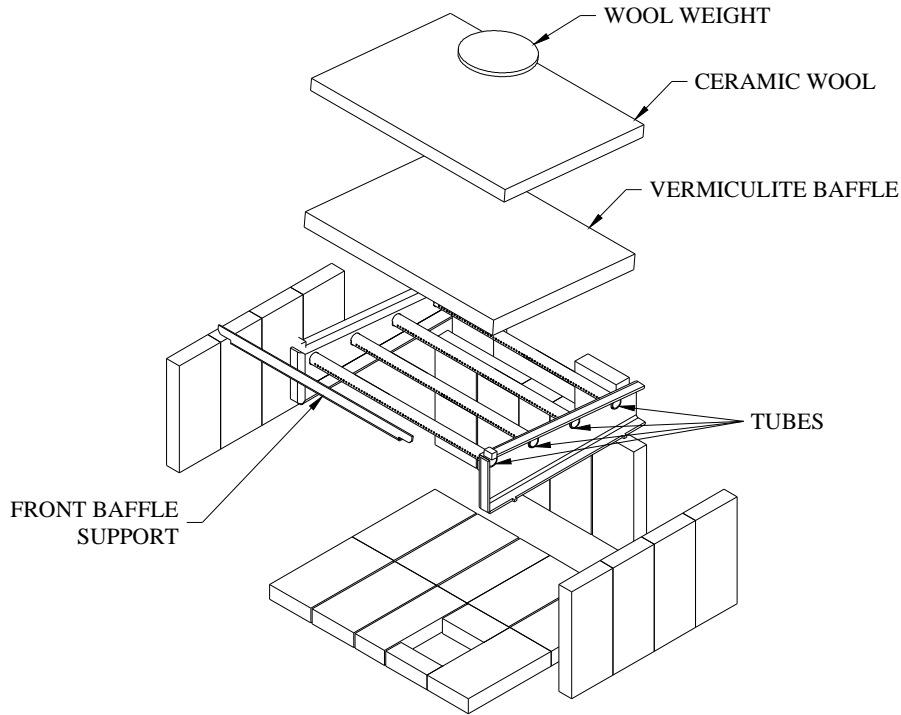


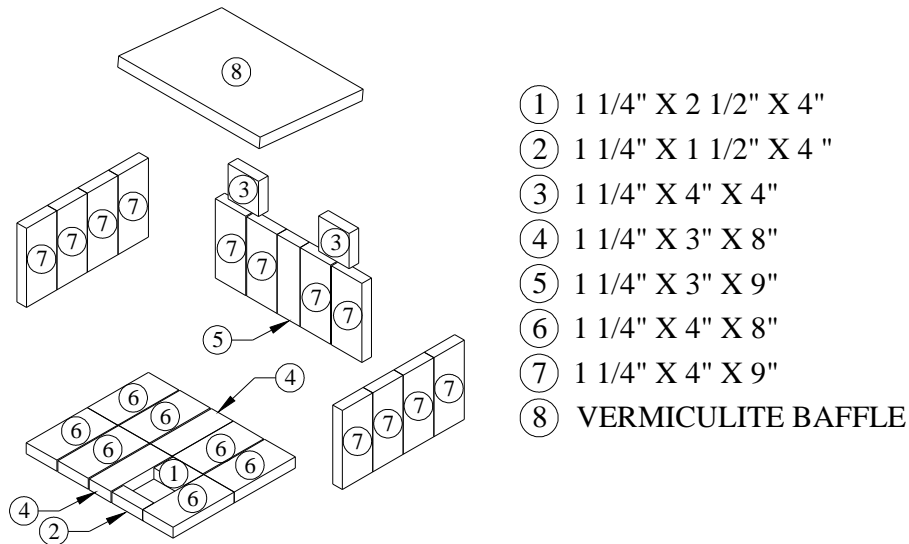
Figure 4.6.2 (B) - Firebrick layout for Solution 1.8 model

## 4.6.2 Baffle installation for Solution 2.9 model

All firebrick and ceramic wool baffles must be properly in place for correct burning operation. Have any damaged firebricks replaced. Check the firebricks annually for damage and replace if they are broken or damaged. See figure 4.6.3 (B) for the firebrick layout.



**Figure 4.6.3 (A) - Baffle installation for Solution 2.9 model**



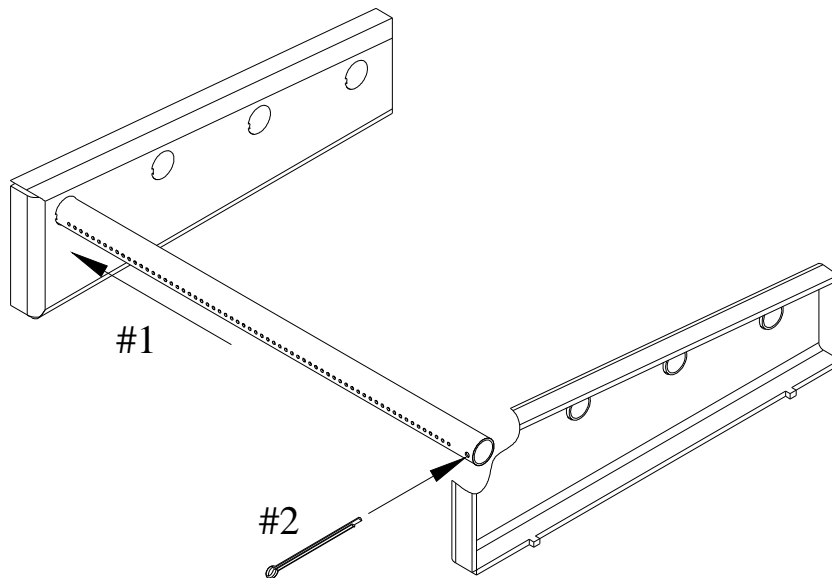
**Figure 4.6.3 (B) - Firebrick layout for Solution 2.9 model**

## 4.7 SECONDARY AIR TUBE REPLACEMENT

(see Figure 4.7)

1. Remove cotter pin at RH end of tube.
2. Slide tube to left and lower tube end below RH plenum.
3. Slide tube to right to remove.
4. Reassemble in reverse order using a new cotter pin. The cotter pin is a hammerlock style and locks into place by hitting the head sharply with a hammer.
5. Note that any tube can be replaced without disturbing the baffle.

### Important Notes:



**Figure 4.7 – Secondary air tube replacement**

The air tubes are identified for placement as follows:

<b>Model</b>	<b>Type of tube</b>
Solution 1.8	Front ► 41 holes of 5/32" Center & rear ► 81 holes of 0.109"
Solution 2.9	All tubes ► 65 holes of 7/64"

## 5. SPECIFICATIONS

### 5.1 SOLUTION 1.8

Fuel Type     Cordwood

Test Standards     ULC S627 & UL 1482 residential.

Recommended surface: 500 to 1800 sq. ft.

Heating capacity\* – BTU/hr., EPA test wood: 34,000 BTU/h.

Heating capacity\* – BTU/hr., seasoned cordwood: 65,000 BTU/h.

Optimum efficiency: 75%

**\*Why is the BTU indicated on the EPA label smaller than the one advertised?**

*You will notice a difference between the BTU output as indicated on the unit's white EPA label affixed to the glass and the BTU as advertised on our web site and/or product literature. The maximum BTU output we advertise for this unit is what will be obtained with a full load of seasoned cordwood inserted inside the firebox. The EPA output, on the other hand, is what has been obtained during emissions testing. The EPA test procedure requires that a special type of wood be used and positioned inside the firebox in a manner that does not represent the way the firebox volume would normally be utilized using seasoned cordwood. The EPA test load is typically much smaller. Hence, the BTU as per the EPA label is reduced. The BTU output that should be considered by a normal user is the one we advertise for seasoned cordwood.*

Shipping Weight	316 lbs (143 kg)
Firebox Volume	1.8 cu.ft. (0,05 m <sup>3</sup> )
Firebox Floor Area	21''W x 13.75''D (533 mm x 349 mm)
Door Opening Size	17.5'' wide x 7.875'' high (445 mm x 200 mm)
Maximum Log Size	20'' (508 mm) if loading sideways
Flue Outlet	6'' (152 mm) diameter (vertical)

## 5.2 SOLUTION 2.9

Fuel Type     Cordwood

Test Standards     ULC S627 & UL 1482 residential.

Recommended surface: 750 to 2300 sq. ft.

Heating capacity\* – BTU/hr., EPA test wood: 29,400 BTU/h.

Heating capacity\* – BTU/hr., seasoned cordwood: 85,000 BTU/h.

Optimum efficiency: 76%

### **\*Why is the BTU indicated on the EPA label smaller than the one advertised?**

*You will notice a difference between the BTU output as indicated on the unit's white EPA label affixed to the glass and the BTU as advertised on our web site and/or product literature. The maximum BTU output we advertise for this unit is what will be obtained with a full load of seasoned cordwood inserted inside the firebox. The EPA output, on the other hand, is what has been obtained during emissions testing. The EPA test procedure requires that a special type of wood be used and positioned inside the firebox in a manner that does not represent the way the firebox volume would normally be utilized using seasoned cordwood. The EPA test load is typically much smaller. Hence, the BTU as per the EPA label is reduced. The BTU output that should be considered by a normal user is the one we advertise for seasoned cordwood.*

Shipping Weight	420 lbs (191 kg)
Firebox Volume	2.9 cu.ft. (0,082 m <sup>3</sup> )
Firebox Floor Area	16.75''W x 19,125''D (425 mm x 486 mm)
Door Opening Size	15.5'' wide x 9.75'' high (398 mm x 248 mm)
Maximum Log Size	19'' (483 mm) if loading sideways
Flue Outlet	6'' (152 mm) diameter (vertical)

# ENERZONE LIMITED LIFETIME WARRANTY

The warranty of the manufacturer extends only to the original retail purchaser and is not transferable. This warranty covers brand new products only, which have not been altered, modified nor repaired since shipment from factory. Proof of purchase (dated bill of sale), model name and serial number must be supplied when making any warranty claim to your ENERZONE dealer.

**This warranty applies to normal residential use only. Damages caused by misuse, abuse, improper installation, lack of maintenance, over firing, negligence or accident during transportation, power failures, downdrafts, venting problems or under-estimated heating area are not covered by this warranty. The recommended heated area for a given appliance is defined by the manufacturer as its capacity to maintain a minimum acceptable temperature in the designated area in case of a power failure.**

This warranty does not cover any scratch, corrosion, distortion, or discoloration. Any defect or damage caused by the use of unauthorized or other than original parts voids this warranty. An authorized qualified technician must perform the installation in accordance with the instructions supplied with this product and all local and national building codes. Any service call related to an improper installation is not covered by this warranty.

The manufacturer may require that defective products be returned or that digital pictures be provided to support the claim. Returned products are to be shipped prepaid to the manufacturer for investigation. Transportation fees to ship the product back to the purchaser will be paid by the manufacturer. Repair work covered by the warranty, executed at the purchaser's domicile by an authorized qualified technician requires the prior approval of the manufacturer. All parts and labour costs covered by this warranty are limited according to the table below.

The manufacturer, at its discretion, may decide to repair or replace any part or unit after inspection and investigation of the defect. The manufacturer may, at its discretion, fully discharge all obligations with respect to this warranty by refunding the wholesale price of any warranted but defective parts. The manufacturer shall, in no event, be responsible for any uncommon, indirect, consequential damages of any nature, which are in excess of the original purchase price of the product. A one-time replacement limit applies to all parts benefiting from lifetime coverage. This warranty applies to products purchased after September 1<sup>st</sup>, 2015.

DESCRIPTION	WARRANTY APPLICATION*	
	PARTS	LABOUR
Combustion chamber (welds only) and cast iron door frame.	Lifetime	5 years
Ceramic glass (thermal breakage only**), secondary air tubes**, plating (manufacturing defect**), and convector air-mate.	Lifetime	N/A
Surrounds, heat shields, ash drawer, steel legs, pedestal, trims (aluminum extrusions), C-Cast baffle**, vermiculite baffle**, removable stainless steel combustion chamber, deflectors, and supports.	7 years	N/A
Handle assembly, glass retainers and air control mechanism.	5 years	3 years
Removable carbon steel combustion chamber components.	5 years	N/A
Standard and optional blower, heat sensors, switches, rheostat, wiring, and other controls.	2 years	1 year
Paint (peeling**), gaskets, insulation, ceramic fiber blankets, firebricks, and other options.	1 year	N/A
All parts replaced under the warranty.	90 days	N/A

*\*Subject to limitations above. \*\*Picture required.*

Labour cost and repair work to the account of the manufacturer are based on a predetermined rate schedule and must not exceed the wholesale price of the replacement part.

Shall your unit or a components be defective, contact immediately your **ENERZONE** dealer. To accelerate processing of your warranty claim, make sure to have on hand the following information when calling:

- Your name, address and telephone number;
- Bill of sale and dealer's name;
- Installation configuration;
- Serial number and model name as indicated on the nameplate fixed to the back of your unit;
- Nature of the defect and any relevant information.

**Before shipping your unit or defective component to our plant, you must obtain an Authorization Number from your ENERZONE dealer. Any merchandise shipped to our plant without authorization will be refused automatically and returned to sender.**